



FUEL MANAGEMENT SYSTEMS



DISPENSERS



KITS



PUMPS



METERS



NOZZLES

K700

FEATURES

- HEAVY DUTY CONDITIONS
- STURDY STRUCTURE
- BURSTING PRESSURE 30 BAR
- NO BATTERY NEEDED
- EASY TO INSTALL
- 2 FLOW DIRECTION

Medium-high flow rates require specific measuring equipment able to adapt precisely to the flow: It is the case of the oval gear mechanical flow meter PIUSI K700: a sturdy, reliable and easy to install equipment suitable for the most demanding environments. The meter displays 4-digit piece of equipment partial total that can show up to a maximum of 9999 liters.

PERFORMANCE

40-220

L/MIN

FLOW RATE

10 BAR

MAX OPERATING

PRESSURE

± 1,5%

ACCURACY

0,3%

REPEATABILITY



K700



PACKAGING

CODE	WEIGHT		PACKAGING			N. BOXES / EUROPALLET	
	KG	LBS	MM	INCH	PCS/BOX	✈	🚚
FO0540000	5,8	12,8	240X240X275	-	1	48	72
FO0540020	5,8	12,8	240X240X275	-	1	48	72
FO0540030	5,8	12,8	240X240X275	-	1	48	72
FO0540040	5,8	12,8	240X240X275	-	1	48	72



FILTRATION



TANK MONITORING



HOSE REEL



ACCESSORIES



MERCHANDISE

PIUSI



ANY BIODIESEL



AIR



ANTIFREEZE



AdBlue®



BIODIESEL



DIESEL



FOOD



GASOLINE



GREASE



KEROSENE



OIL



WATER



WINDSCREEN

CHART

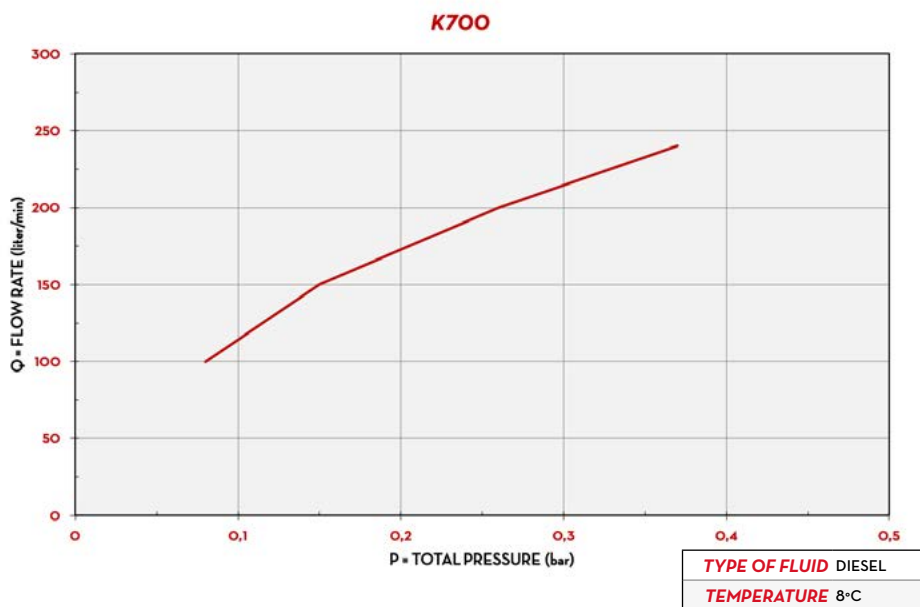

DIMENSIONS

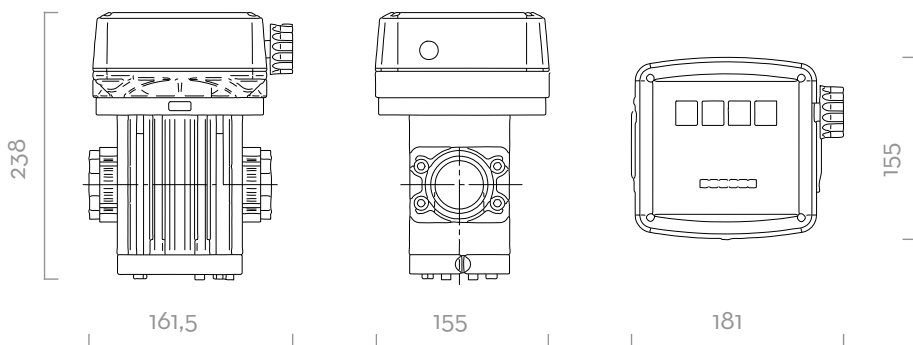

Dimensions expressed in millimeters

IN THE BOX

- K700 METER
- INSTRUCTION MANUAL

DETAILS



MATERIALS

- BODY: ALUMINIUM
- GEARS: TECHNOPOLYMER

TECHNICAL DATA

CODE	DESCRIPTION	FLUIDS TYPE	FLOW DIRECTION	FLOW RATE		PRESSURE		INLET FILTER	INLET / OUTLET
				L/MIN	GPM	BAR	PSI		
FO0540000	K700 VER. A	D		40 - 220	5 - 53	10	142	YES	1" 1/2 BSP
FO0540020	K700 VER. B	D		40 - 220	5 - 32	10	142	YES	1" 1/2 BSP
FO0540030	K700 VER. C	D		40 - 220	5 - 53	10	142	YES	1" 1/2 BSP
FO0540040	K700 VER. D	D		40 - 220	5 - 32	10	142	YES	1" 1/2 BSP